



Shelby Industries
P.O. Box 308
Industrial Park
Shelbyville, Ky. 40066-0308

MODEL 5480A 5481A

WINCH Operation Maintenance Instructions Parts List



CAUTION



THIS WINCH IS NOT DESIGNED TO BE USED FOR HOISTING OR TRANSFER OF PEOPLE OR HOISTING LOADS OVER PEOPLE-OCCUPIED AREAS.

1. NEVER leave a weight hanging by the winch while the winch is unattended, as unauthorized persons may attempt to operate the winch, thereby creating an unsafe condition.
2. NEVER exceed maximum rated line pull (stamped on winch). Exceeding this rating could cause failure of the winch, serious injury to the operator, bystanders and damage to equipment.

NOTE: Maximum rated line pull for Model 5480A and 5481A is 3200 lbs. for the first layer (minimum of 3 wraps) of line on the drum.
As more line is wrapped on the drum, the mechanical advantage of the winch is reduced and the rating will also be reduced.

3. ALWAYS keep winch maintained in accordance with this instruction sheet. REMEMBER: Worn parts cause unsafe conditions.
4. Winch components can be affected by chemicals, salts and rust and should be examined for unsafe conditions before operating.
5. NEVER alter the mechanics of the winch (Example: do not add to the handle length to make easier lifting.)
6. NEVER use two or more winch units to lift a load that is greater than the load rating of any single unit. A shifting load may place the entire load on one unit, causing sudden failure of equipment, property damage and serious injury.
7. Apply the load evenly. Do not jerk or bounce the load or allow the load to swing. Avoid violent motion and shock loads. This type of operation requires equipment with higher load ratings.
8. Each time a load is to be lifted, test winch for safe operation by lifting the load a few inches first.
9. ALWAYS keep hands away from load-bearing cables, ropes, sheaves, drums and pulleys while operating.
10. ALWAYS be sure cable is strong enough to support the load to be lifted.
11. ALWAYS inspect cable and attachment hook before each use to insure they are not damaged.
12. Replace cable if worn, frayed or kinked. If cable or hook breaks, the cable can act like a whip and inflict serious injury to anyone in the path of its movement.
13. NEVER stand alongside winch cable, or guide the cable with your hands.
14. NEVER fully extend cable and ALWAYS keep three (3) complete wraps of cable around drum.
15. ALWAYS be sure cable is pulling straight off winch – not at an angle. This will prevent cable from rubbing against winch drum, avoiding cable damage.

CAUTION: DO NOT RELEASE HANDLE UNLESS RATCHET PAWL IS PROPERLY ENGAGED. DO NOT DISENGAGE RATCHET PAWL UNLESS TENSION IS APPLIED TO HANDLE. FAILURE TO OBSERVE THESE CAUTIONS WILL CAUSE HANDLE TO SPIN OUT OF CONTROL AND COULD CAUSE PERSONAL INJURY.



CAUTION: CARE MUST BE TAKEN DURING REASSEMBLY TO INSURE THAT ALL PARTS ARE INSTALLED CORRECTLY FOR PROPER OPERATION.

PARTS LIST:

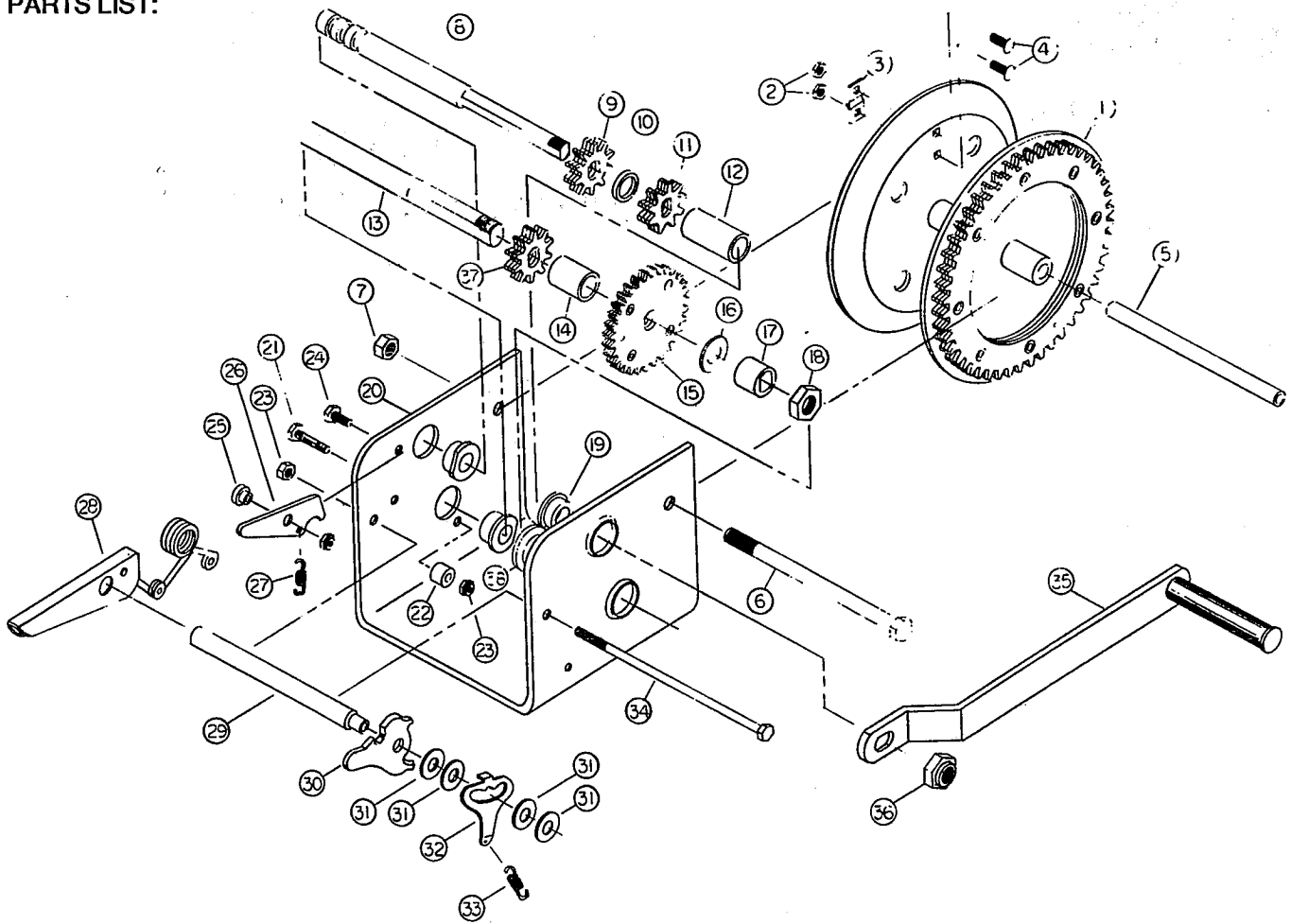

<u>ITEM</u>	<u>DESCRIPTION</u>	<u>PART NO.</u>	<u>QTY.</u>	<u>ITEM</u>	<u>DESCRIPTION</u>	<u>PART NO.</u>	<u>QTY.</u>
1	Reel Assembly	2412-11	1	19	Bushing	2679-09	3
2	Hex Nut	2706-03	2	20	Frame	2404-00	1
3	Cable Keeper	2704-03	1	21	Hex Bolt-1/4	0913-03	1
4	Carriage Bolt	2705-03	2	22	Spacer	2437-09	1
5	Reel Spacer	2417-08	1	23	Hex Nut-1/4	0672-03	3
6	Hex Bolt	2418-03	1	24	Hex Bolt-1/4	0796-03	1
7	Lock Nut	2419-03	1	25	Spacer	0936-03	1
8	Pinion Shaft	2422-03	1	26	Locking Lever	2434-03	1
9	Pinion Gear	0776-03	3	27	Spring	0660-00	1
10	Spacer	2428-09	1	28	Brake Handle	2443-11	1
11	9T-Pinion Gear	2424-03	3	29	Posi-Lock Tube	2435-03	1
12	Spacer	2429-09	1	30	Posi-Lock	0888-00	1
13	Inter. Shaft	2485-03	1	31	Washer	0904-03	5
14	Spacer	2487-09	1	32	Posi-Lock Cam	0897-03	1
15	Inter. Gear Asm.	2489-11	1	33	Spring	0662-00	1
16	Washer	2490-03	1	34	Hex Bolt-1/4	2436-03	1
17	Bearing Race	2491-09	1	35	Handle	2400-11	1
18	Lock Nut-3/4	2493-03	1	36	Lock Nut	0673-03	1
				37	Pinion Gear	2486-03	4
				38	Bushing	2492-09	1

WARNING: This equipment should not be installed, operated or maintained by any individual who has not read all the contents of this owner's operating manual.

Failure to read and apply the instruction and warnings contained herein can result in sudden failure of equipment, property damage and serious injury.